

WNS 18swg Pittsburgh Lock Rollformer (RF18)

Manufactured by **W. NEAL SERVICES LTD.**

W. NEAL SERVICES LTD
 29 Purdeys Way
 Purdeys Industrial Estate
 Rochford
 Essex
 SS4 1ND
 ENGLAND



WNS 18swg Pittsburgh Lock Rollformer (RF18)
 Detailed photographs shown with optional Flanging Attachment.



WNS 18swg (1.2mm) PITTSBURGH LOCK ROLLFORMERS are 7 station machines. They are principally used in the HVAC industry for joining sheet metal at right angles on straight and curved duct sections. Pittsburgh Lock Rolls and auxiliary shafts are fitted as standard with the option of a flanging attachment if required. The 'lock' is formed in one pass and a flange is inserted into the pocket. The edge is then hammered over either manually or with a **WNS PITTSBURGH LOCK SEAM CLOSER / LOCKER (SC10) & (SC12)** or with a **WNS 18swg (1.2mm) PITTSBURGH LOCK AIR CLOSING HAMMER (AH18)**. Additional forming rolls, such as double seam rolls, drive cleat rolls, etc. can be fitted onto the auxiliary shafts. A flanging attachment is also available and can be fitted as an optional extra. This enables a right angle to be formed on curved, straight and irregular shapes. The attachment is fitted with a tilting head to enable complete circles to be formed.

WNS Rollformers are manufactured with all steel side plates. The shafts, forming rolls, gears and guide fences are all hardened, and needle bearings are fitted throughout.

SPECIFICATIONS

Model:	Speed:	Flanging Attachment Direction:	Motor Power:	Supply Voltage:	Length:	Width:	Height (with FA):	Weights - net/gross:
RF18	6.0m/min	Left to Right	2HP, 1.5kW	415v, 3 Phase	1450mm	615mm	1000mm (1140mm)	265Kg/325Kg

Revised: Aug 2020

All capacities are based on the use of Rollforming quality Mild Steel. All specifications, dimensions and weights are approximate and are to be used as a guide. Colours may vary. W. Neal Services Ltd reserves the right to alter any specifications. E&OE.

WNS 18swg Pittsburgh Lock Rollformer (RF18)

Manufactured by **W. NEAL SERVICES LTD.**

W. NEAL SERVICES LTD
 29 Purdeys Way
 Purdeys Industrial Estate
 Rochford
 Essex
 SS4 1ND
 ENGLAND

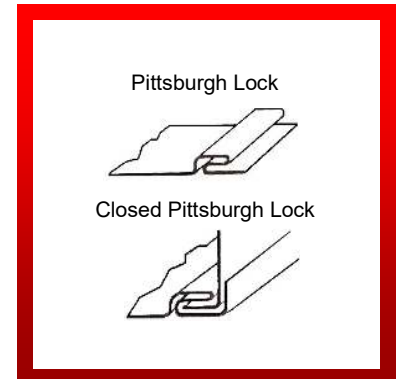
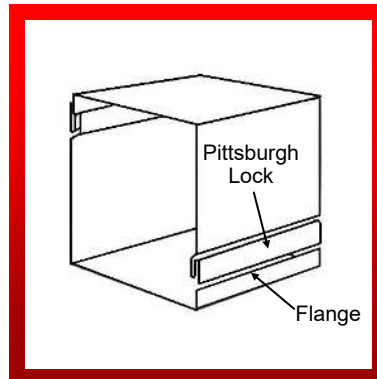
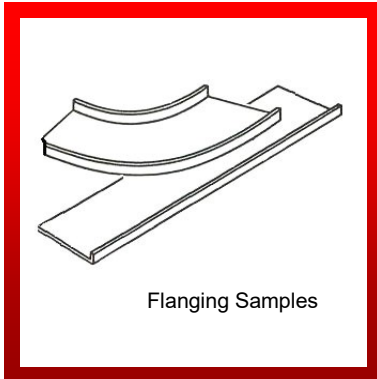

*Optional Rolls which can be fitted to auxiliary shafts.

CE

SPECIFICATIONS										
Auxiliary Rolls:	Pittsburgh Lock Rolls Fitted Inboard:	Small Pittsburgh Lock*:	Drive Cleat*:	Double Seam*:	Plain Seam*:	Right Angle Flange*:	Standing Seam*:	3 in 1*:	Safe Edge*:	Closed Double Seam*:
Sections:	 (Standard)									
Maximum Thickness:	1.6mm	0.8mm	1.0mm	1.2mm	1.0mm	1.6mm	0.8mm	0.8mm	0.8mm	1.2mm
Material Used (apx):	30mm <small>(Subject to knock over edge)</small>	25mm	54mm	32mm	11mm	11mm	54mm	-	-	32mm
Seam Width:	13mm	10mm	29mm	13mm	10mm	-	-	-	8.0mm	13mm
Flange Height:	-	-	-	-	-	Max. 12mm	-	-	-	-
Seam Height:	-	-	-	-	-	-	19mm	15mm	-	-

Other Products in our range....



All capacities are based on the use of Rollforming quality Mild Steel. All specifications, dimensions and weights are approximate and are to be used as a guide. Colours may vary. W. Neal Services Ltd reserves the right to alter any specifications. E&OE.